

honors
(not AP®)

Heat Engines

Unit: Thermodynamics

NGSS Standards/MA Curriculum Frameworks (2016): HS-PS2-6

AP® Physics 2 Learning Objectives/Essential Knowledge (2024): N/A

Mastery Objective(s): (Students will be able to...)

- Calculate the energy produced or used by a heat engine.

Success Criteria:

- Correct equation is chosen.
- Solutions have the correct quantities substituted for the correct variables.
- Sign is correct for work (positive vs. negative).
- Algebra is correct.

Language Objectives:

- Explain what is happening to a gas through each of the steps of a heat engine cycle.

Tier 2 Vocabulary: internal, energy, heat, engine, work

Labs, Activities & Demonstrations:

- Stirling engine

Notes:

heat engine: a device that turns heat energy into mechanical work.

A heat engine operates by taking heat from a hot place (heat source), converting some of that heat into work, and dumping the rest of the heat into a cooler reservoir (heat sink).

A large number of the machines we use—most notably cars—employ heat engines.

*honors
(not AP®)*

The basic principle of heat engine is the first law of thermodynamics (heat flows from a region of higher temperature to a region of lower temperature). Because heat is a form of energy, some of that energy can be harnessed to do work.

The law of conservation of energy tells us that all of the energy that we put into the heat engine must go somewhere. Therefore, the work done plus the heat that comes out must equal the heat we put in.

This means:

$$Q_{in} = Q_{out} + W_{out}$$

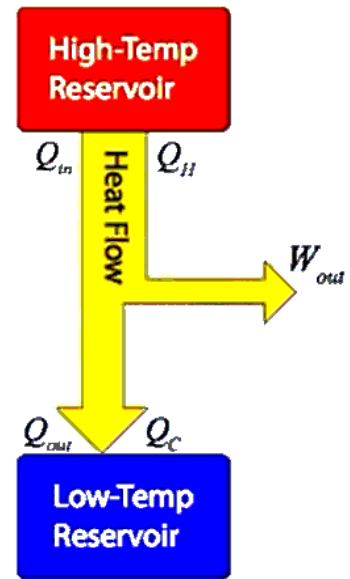

The above picture is easier to understand in the context of a PV diagram.

- Starting from point 1 (V_1, P_1), the gas is expanded adiabatically (without losing heat) to point 2 (V_2, P_2). The area under the graph from point 1–2 represents the work that is done by the gas (W_{out}) as it expands and cools.

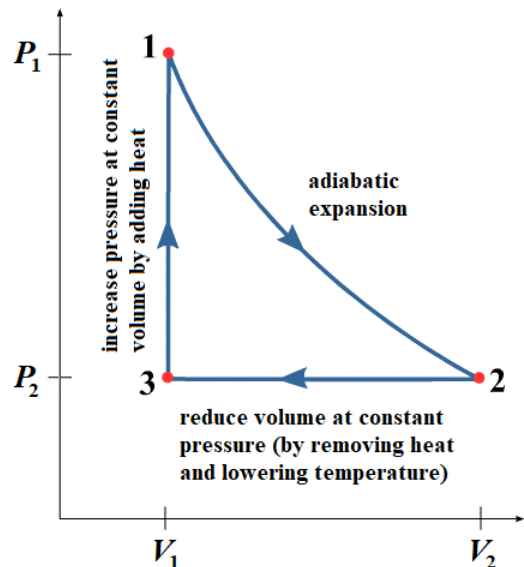

- Ultimately, we need to get the gas back to point 1 so we can begin the cycle over again, but in a way that costs less work than we got out. There are many ways to accomplish this. In this example, the next step is to reduce the volume isobarically, by removing heat (Q_{out}). (This is what the low temperature reservoir is for.) This results in a decrease in temperature as well as a decrease in volume, which gets us to point 3 (V_1, P_2).
- Now we increase the pressure to get from point 3 (V_1, P_2) to point 1 (V_1, P_1) by adding heat to the gas without letting the volume change. We do this by bringing the gas back to the high temperature reservoir so it can absorb the heat (Q_{in}).

honors
(not AP®)

Heat Pumps

A heat pump is a device, similar to a heat engine, that “pumps” heat from one place to another. A refrigerator and an air conditioner are examples of heat pumps. A refrigerator uses a fluid (“refrigerant”) to transfer (or “pump”) heat from the inside of the refrigerator to the outside of the refrigerator (and into your kitchen).

This is why you can’t cool off the kitchen by leaving the refrigerator door open—even if you had a 100 % efficient refrigerator (most refrigerators are actually only 20–40 % efficient), all of the heat that you pumped out of the refrigerator is still in the kitchen!

A refrigerator works by the following process.

1. Work is put in to compress a refrigerant (gas). In most cases, the gas is compressed until it turns into a liquid, which means additional energy is stored in the phase change. This increases the temperature of the refrigerant to about 70 °C.
2. The refrigerant (now a liquid) passes through cooling coils on the back of the refrigerator. The liquid is cooled through convection by the air in the kitchen to about 25 °C
3. The refrigerant (still a liquid) is pumped to the inside of the refrigerator and allowed to expand to a gas adiabatically. Work comes out of the gas, and the temperature drops to about –20 °C.
4. Heat is transferred via convection from the contents (the food) to the refrigerant.
5. The refrigerant (still a gas) is pumped out of the refrigerator, which brings us back to step 1.

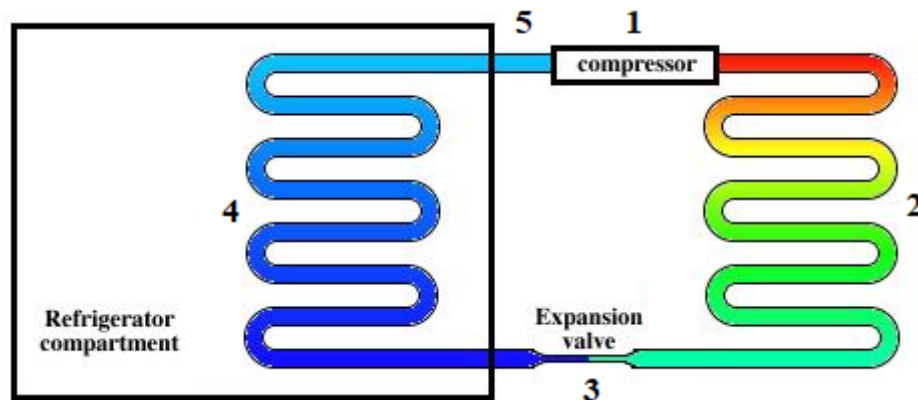

A heater can operate under the same principle, by putting the cooling coils inside the room and having the expansion (which cools the refrigerant) occur outside. Individual rooms in homes are sometimes heated and cooled by reversible heat pumps called “mini-splits”.

honors
(not AP®)

Heat Engines and PV Diagrams

On a PV diagram, a heat engine is any closed loop or cycle:

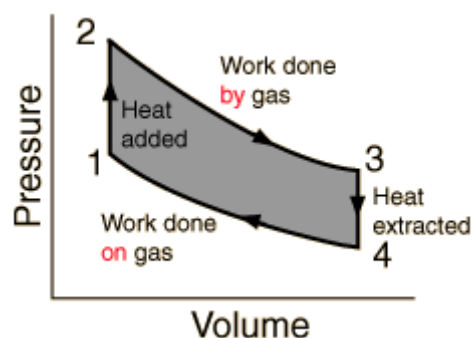

Recall that on a PV diagram, a curve that moves from left to right represents work done by the gas on the surroundings. (Work is leaving the system, so $\Delta W < 0$.) A curve that moves from right to left represents work done on the gas by the surroundings. (Work is entering the system so $\Delta W > 0$.)

A heat engine is a clockwise cycle, which means more work is done going to the right than to the left, which means there is a net flow of work out of the system (*i.e.*, the heat is being used to do work). A refrigerator is a counterclockwise cycle, in which more work is put in and more heat is taken out.

The Carnot cycle, named after the French physicist Nicolas Carnot, is the most efficient type of heat engine. The Carnot cycle, which uses only adiabatic (no heat loss) and isothermal processes, is the basis for heat pumps (including refrigerators and air conditioners) :

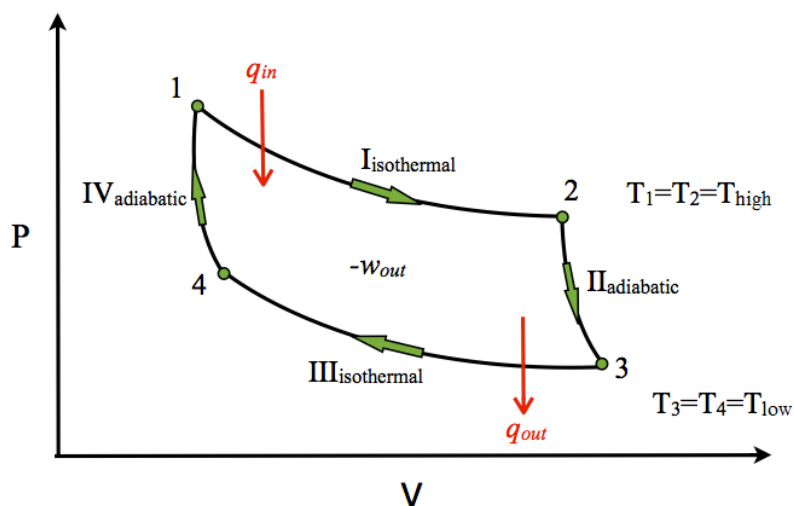

honors
(not AP®)

The internal combustion engine in a car is also a type of heat engine. The engine is called a “four-stroke” engine, because the piston makes four strokes (a back or forth motion) in one complete cycle. The four strokes are:

1. The piston moves down (intake), sucking a mixture of gasoline and air into the cylinder.
2. The piston moves up (compression), compressing the gases in the cylinder.
3. The spark plug creates a spark, which combusts the gases. This increases the temperature in the cylinder to approximately 250°C.
4. The gas expands (power stroke), which is the work that the engine provides to make the car go.
5. The piston raises again, forcing the exhaust gases out of the cylinder (exhaust).

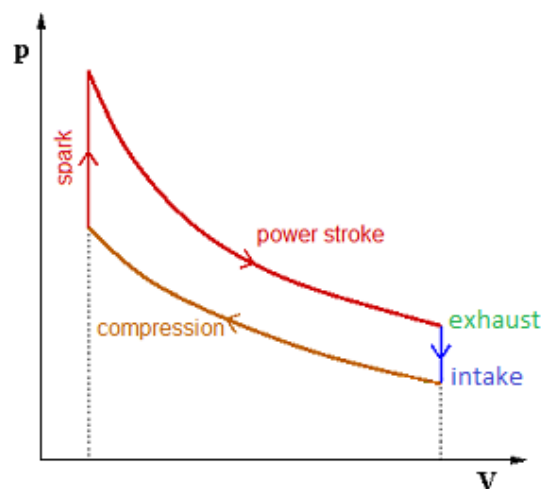

Note that, at the end of the cycle, the gas is hotter than its original temperature. The hot gas from the cylinder is dumped out the exhaust pipe, and fresh (cool) gas and fuel is added. This is why the blue intake arrow on the right moves downward—the intake is at a lower temperature (lower isotherm).

The energy to move the piston for the intake and exhaust strokes is provided by the power strokes of the other pistons.

This cycle—constant temperature compression, constant volume heating (spark), constant temperature expansion (power), and constant volume gas exchange (exhaust) is called the Otto cycle, named after Nikolaus August Otto, who used this type of heat engine to build the first commercially successful internal combustion engine.