

Kirchhoff's Rules

Unit: DC Circuits

NGSS Standards/MA Curriculum Frameworks (2016): HS-PS2-9(MA)

AP[®] Physics 2 Learning Objectives/Essential Knowledge (2024): 11.6.A, 11.6.A.1, 11.6.A.2, 11.6.A.3, 11.6.A.4, 11.7.A, 11.7.A.1, 11.7.A.2

Mastery Objective(s): (Students will be able to...)

- Apply Kirchhoff's junction and loop rules to determine voltages and currents in circuits.

Success Criteria:

- Loop rule correctly applied (electric potential differences add to zero).
- Junction rule correctly applied (total current into a junction equals total current out).

Language Objectives:

- Explain why electric potential has to add to zero around a loop and why current into a junction has to add up to current out.

Tier 2 Vocabulary: loop, junction

Labs, Activities & Demonstrations:

- model a circuit by walking up & down stairs

Notes:

In 1845, the German physicist Gustav Kirchhoff came up with two simple rules that describe the behavior of current in complex circuits. Those rules are:

Kirchhoff's junction rule: the total current coming into a junction must equal the total current coming out of the junction.

The junction rule is based on the concept of conservation of electric charge. Current is simply the flow of electric charge, so any charges that come into a junction must also come out of it.

Kirchhoff's loop rule: the sum of the voltages around a closed loop must add up to zero.

The loop rule is based on the concept that voltage is the difference in electric potential between one location in the circuit and another. If you come back to the same point in the circuit, the difference in electric potential between where you started and where you ended (the same place) must be zero. Therefore, any increases and decreases in voltage around the loop must cancel.

Junction Rule Example:

As an example of the junction rule, consider the following circuit:

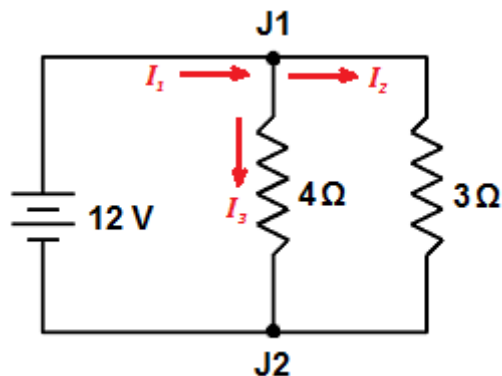

The junction rule tells us that the current flowing into junction J1 must equal the current flowing out. If we assume current I_1 flows into the junction, and currents I_2 and I_3 flow out of it, then $I_1 = I_2 + I_3$.

We know that the voltage across both resistors is 12 V. From Ohm's Law we can determine that the current through the 3 Ω resistor is $I_2 = 4 \text{ A}$, and the current through the 4 Ω resistor is $I_3 = 3 \text{ A}$. The junction rule tells us that the total current must therefore be:

$$I_1 = I_2 + I_3 = 4 \text{ A} + 3 \text{ A} = 7 \text{ A} .$$

Loop Rule Example:

For the loop rule, consider the circuit to the right:

If we start at point A and move counterclockwise around the loop (in the direction of the arrow), the voltage should be zero when we get back to point A.

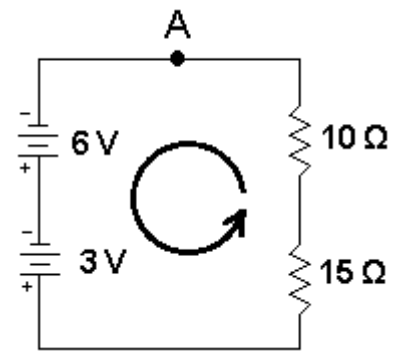

For this example, we are moving around the circuit in the same direction that the current flows, because that makes the most intuitive sense. However, it wouldn't matter if we moved clockwise instead—just as with vector quantities, we choose a positive direction and assign each quantity to a positive or negative number accordingly, and the math tells us what is actually happening.

Starting from point A, we first move through the 6 V battery. We are moving from the negative pole to the positive pole of the battery, so the voltage increases by +6V. When we move through the second battery, the voltage increases by +3V.

Next, we move through the 15 Ω resistor. When we move through a resistor in the positive direction (of current flow), the voltage drops, so we assign the resistor a voltage of $-15I$ (based on $V = IR$, where I is the current through the resistor).

Similarly, the voltage across the 10 Ω resistor is $-10I$. Applying the loop rule gives:

$$\begin{aligned} 6 + 3 + (-15I) + (-10I) &= 0 \\ 9 - 25I &= 0 \\ 9 &= 25I \\ I &= \frac{9}{25} = 0.36 \text{ A} \end{aligned}$$

Now that we know the total current, we can use it to find the voltage drop (potential difference) across the two resistors.

$$\Delta V_{10\Omega} = IR = (0.36)(10) = 3.6 \text{ V} \quad \Delta V_{15\Omega} = IR = (0.36)(15) = 5.4 \text{ V}$$

Sample Problem using Kirchhoff's Rules:

Find the voltage and current across each resistor in the following circuit:

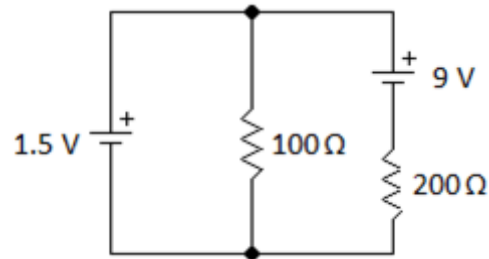

Applying the junction rule, we choose arbitrary directions for current:

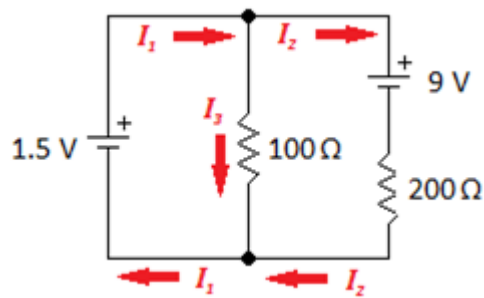

$$I_1 = I_2 + I_3$$

By closer inspection, we can see that the direction for I_2 is probably going to be wrong. This means we expect that I_2 will come out to a negative number.

Now that we have defined the directions for current using the junction rule, we apply the loop rule. Again, we choose the direction of each loop arbitrarily, without worrying about which direction we have

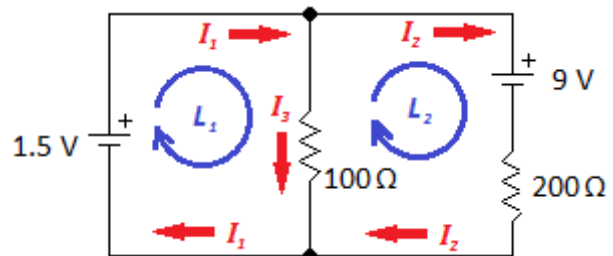

chosen for current. The loop direction is simply the order in which we inspect each element. The numbers will be determined by the direction we chose for current.

As we inspect our way around the loop, there are two rules for determining the voltage across each component:

1. Voltage across a battery is *positive* if the loop direction is *from negative to positive* (the "forward" direction).
Voltage across a battery is *negative* if the loop direction is *from positive to negative* (the "backward" direction).
2. Voltage across a resistor is *negative* if the loop direction is *with the current* (the resistor is "using up" voltage).
Voltage across a resistor is *positive* if the loop direction is *against the current* (we are traveling from a place where the electric potential is lower to a place where it is higher).

Now we inspect our way around each loop, writing the equations for the voltages:

$$\text{L1: } +1.5 - 100I_3 = 0 \rightarrow I_3 = 0.015 \text{ A}$$

$$\text{L2: } -9 - 200I_2 + 100I_3 = 0$$

$$-9 - 200I_2 + 1.5 = 0$$

$$-7.5 = 200I_2$$

$$I_2 = -0.0375 \text{ A}$$

$$I_1 = I_2 + I_3 = -0.0375 + 0.015 = -0.0225 \text{ A}$$

I_3 came out to a positive number, meaning that the current is flowing in the direction that we chose initially. However, I_1 and I_2 both came out negative, meaning that the current in those two segments of the circuit is actually flowing in the opposite direction from the arbitrary direction that we chose at the beginning of the problem.

Now that we know the current and resistance, we can find the voltage drop across each resistor using Ohm's Law.

$$100 \Omega: \quad V = I_3 R = (0.015)(100) = 1.5 \text{ V}$$

$$200 \Omega: \quad V = I_2 R = (-0.0375)(200) = -7.5 \text{ V}$$

Again, the negative sign shows that the voltage drop (from positive to negative) is in the opposite direction from what we originally chose.