

Circuits

Unit: DC Circuits

MA Curriculum Frameworks (2016): HS-PS2-9(MA)

AP® Physics 2 Learning Objectives: 4.E.4.1

Mastery Objective(s): (Students will be able to...)

- Identify electrical circuits or sections of circuits as series or parallel.

Success Criteria:

- Descriptions correctly identify the component.
- Descriptions correctly describe which type of circuit (series or parallel) the component is in.

Language Objectives:

- Identify which components are in series vs. parallel in a mixed circuit.

Tier 2 Vocabulary: series, parallel

Labs, Activities & Demonstrations:

- Example circuit with light bulbs & switches.
- Fuse demo using a single strand from a multi-strand wire.

Notes:

circuit: an arrangement of electrical components that allows electric current to pass through them so that the tasks performed by the individual components combine in some useful way.

closed circuit: a circuit that has a complete path for current to flow from the positive terminal of the battery or power supply through the components and back to the negative terminal.

open circuit: a circuit that has a gap such that current cannot flow from the positive terminal to the negative terminal.

short circuit: a circuit in which the positive terminal is connected directly to the negative terminal with no load (resistance) in between.

Use this space for summary and/or additional notes:

A diagram of a simple electric circuit might look like the diagram to the right.

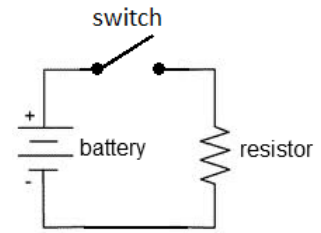

When the switch is closed, the electric current flows from the positive terminal of the battery through the switch, through the resistor, and back to the negative terminal of the battery.

An electric circuit needs a power supply (often a battery) that provides current at a specific voltage (electric potential difference), and one or more components that use the energy provided.

The battery or power supply continues to supply current, provided that:

1. There is a path for the current to flow from the positive terminal to the negative terminal, and
2. The total resistance of the circuit is small enough to allow the current to flow.

If the circuit is broken, current cannot flow and the chemical reactions inside the battery stop.

As circuits become more complex, the diagrams reflect this increasing complexity. The following is a circuit diagram for a metal detector:

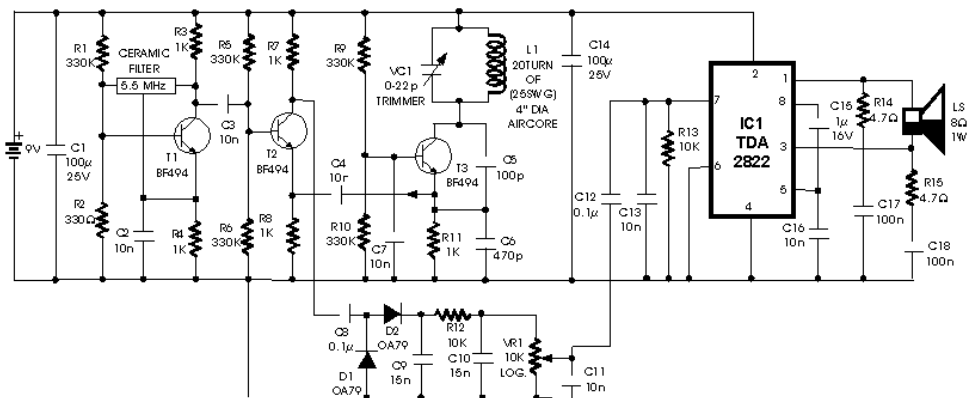

Analyzing an electrical circuit means figuring out the potential difference (voltage), current, and/or resistance contributed by each component of a circuit.

Use this space for summary and/or additional notes:

Series vs. Parallel Circuits

If a circuit has multiple components, they can be arranged in series or parallel.

series: Components in series lie along the same path, one after the other.

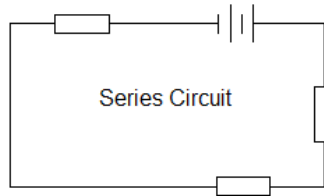

parallel: Components in parallel lie in separate paths.

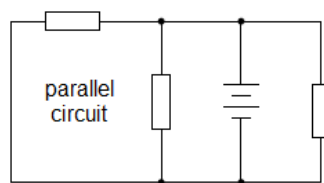

Note that complex circuits may have some components that are in series with each other and other components that are in parallel.

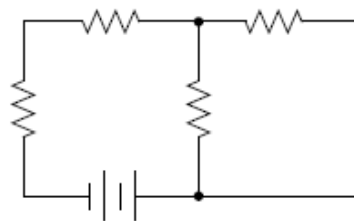

Use this space for summary and/or additional notes:

Sample Problem:

Q: A circuit consists of a battery, two switches, and three light bulbs. Two of the bulbs are in series with each other, and the third bulb is in parallel with the others. One of the switches turns off the two light bulbs that are in series with each other, and the other switch turns off the entire circuit. Draw a schematic diagram of the circuit, using the correct symbol for each component.

A:

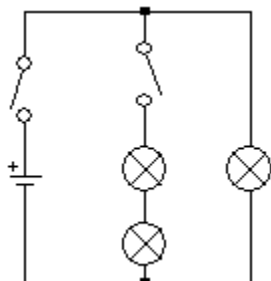

Note that no sensible person would intentionally wire a circuit this way. It would make much more sense to have the second switch on the branch with the one light bulb, so you could turn off either branch separately or both branches by opening both switches. This is an example of a strange circuit that a physics teacher would use to make sure you really can follow exactly what the question is asking!

Use this space for summary and/or additional notes:

Homework Problems

1. **(M)** The circuit shown to the right contains a battery, switch (SW1), capacitor (C1), and resistor (R1). Which of components C1 and SW1 are in series with R1? Which are in parallel with R1?

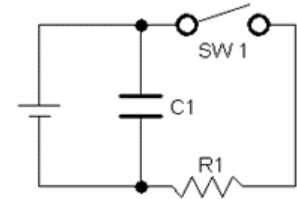

2. **(M)** The circuit shown to the right contains a battery and four resistors (R1, R2, R3, and R4). Which resistors are in series with R1? Which are in parallel with R1?

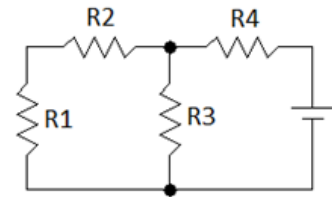

3. **(M)** The following bizarre circuit contains three batteries and a light bulb. What is the potential difference across the light bulb?
(Hint: remember to check the +/- orientation of the batteries.)

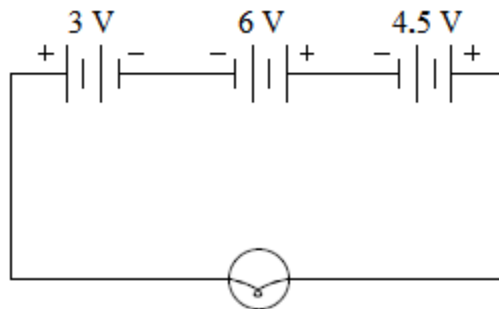

Answer: 7.5 V

Use this space for summary and/or additional notes: