

Measuring Voltage, Current & Resistance

Unit: DC Circuits

MA Curriculum Frameworks (2016): N/A

AP® Physics 2 Learning Objectives: 4.E.5.3

Mastery Objective(s): (Students will be able to...)

- Accurately measure voltage and current in a DC circuit.

Success Criteria:

- Multimeter wires are plugged in to the correct jacks and dial is set to the correct quantity.
- Measurements are taken at appropriate points in the circuit. (Voltage is measured in parallel and current is measured in series.)

Language Objectives:

- Explain how to set up the multimeter correctly.
- Explain where to take the measurements and why.

Tier 2 Vocabulary: meter

Labs, Activities & Demonstrations:

- Show & tell with digital multi-meter.
- Measurement of voltages and currents in a live DC circuit.

Notes:

Analyzing an electrical circuit means figuring out the potential difference (voltage), current, and/or resistance in each component of a circuit. In order to analyze actual circuits, it is necessary to be able to measure these quantities.

Measuring Voltage

Suppose we want to measure the electric potential (voltage) across the terminals of a 6 V battery. The diagram would look like this:

The voltage between points A and B is either +6 V or -6 V, depending on the direction. The voltage from A to B (positive to negative) is +6 V, and the voltage from B to A (negative to positive) is -6 V.

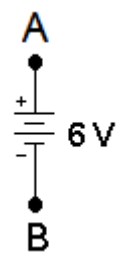

Use this space for summary and/or additional notes:

To measure voltage:

1. The circuit needs to be powered up with current flowing through it.
2. Make sure the red lead is plugged into the $V\Omega$ socket (for measuring volts or ohms).
3. Make sure that the voltmeter is set for volts (DC or AC, as appropriate).
4. Touch the two leads *in parallel* with the two points you want to measure the voltage across. (Remember that voltage is the same across all branches of a parallel circuit. You want the voltmeter to be one of the branches, and the circuit to be the other branch with the same voltage.)

On a voltmeter (a meter that measures volts or voltage), positive voltage means the current is going from the red (+) lead to the black (-) lead. In the following circuit, if you put the red (+) lead on the end of a resistor that is closer to the positive terminal of the battery, and the black (-) lead on the end that is closer to the negative terminal, the voltage reading will be positive. In this circuit, the voltmeter reads +6V:

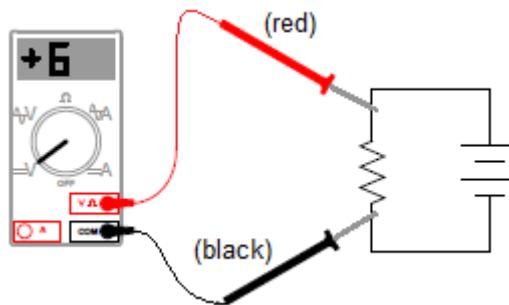

However, if you reverse the leads so that the black (-) lead is closer to the positive terminal and the red (+) lead is closer to the negative terminal, the voltage reading will be negative. In this circuit, the voltmeter reads -6V:

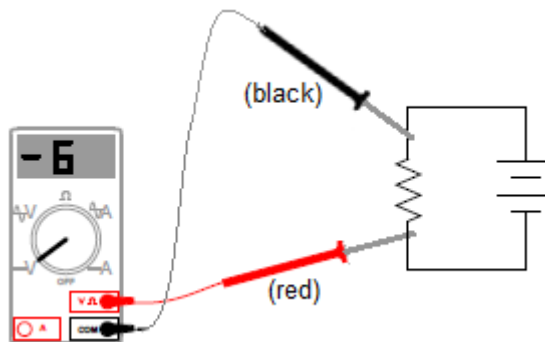

The reading of -6V indicates that the current is actually flowing in the opposite direction from the way the voltmeter is measuring—from the black (-) lead to the red (+) lead.

Use this space for summary and/or additional notes:

Measuring Current

To measure current:

1. The circuit needs to be open between the two points where you want to measure the current.
2. Make sure the red lead is plugged into appropriate socket (10 A if the current is expected to be 0.5 A or greater; 1 A or mA/ μ A if the current is expected to be less than 0.5 A).
3. Make sure the ammeter is set for amperes (A), milliamperes (mA) or microamperes (μ A) AC or DC, depending on what you expect the current in the circuit to be.
4. Touch one lead to each of the two contact points, so that the ammeter is *in series* with the rest of the circuit. (Remember that current is the same through all components in a series circuit. You want to measure all of the current, so you want all of the current to flow through the meter.)

On an ammeter (a meter that measures current), the current is measured assuming that it is flowing from the red (+) lead to the black (-) lead. In the following circuit, if you put the red (+) lead on the side that is connected to the positive terminal and the black (-) lead on the end that is connected to the negative terminal, the current reading would be positive. In this circuit, the current is +3 A:

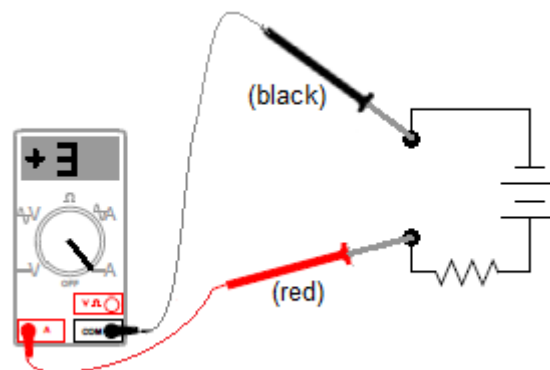

As with the voltage example above, if you switched the leads, the reading would be -3 A instead of +3 A.

Use this space for summary and/or additional notes:

Measuring Resistance

Resistance does not have a direction. If you placed an ohmmeter (a meter that measures resistance) across points A and B, it would read $10\ \Omega$ regardless of which lead is on which point.

An ohmmeter supplies a voltage across the component and measures the current. Because the voltage supplied is constant, the Ohm's Law calculation is built into the meter and the readout displays the resistance.

To measure resistance:

1. The circuit needs to be open. Because the meter is applying a voltage and measuring current, you do not want other voltages or currents in the circuit.
2. Make sure the red lead is plugged into the $V\ \Omega$ socket (for measuring volts or ohms).
3. Make sure that the voltmeter is set for Ω .
4. Touch one lead to each end of the resistor.

It is sometimes easier and/or more reliable to measure the voltage and current and calculate resistance using Ohm's Law ($V = IR$).

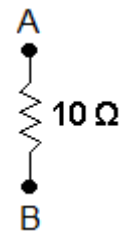

Use this space for summary and/or additional notes: