

Capacitors in Series and Parallel Circuits

Unit: DC Circuits

MA Curriculum Frameworks (2016): N/A

AP[®] Physics 2 Learning Objectives: 4.E.4.1, 4.E.4.2, 4.E.4.3, 4.E.5.1, 4.E.5.2, 4.E.5.3

Mastery Objective(s): (Students will be able to...)

- Calculate voltage, capacitance, charge and potential energy in series and parallel circuits.

Success Criteria:

- Correct relationships are applied for each quantity
- Variables are correctly identified and substituted correctly into the correct equations and algebra is correct.

Language Objectives:

- Explain how capacitors behave similarly to and different from resistors in series and parallel circuits.

Tier 2 Vocabulary: charge, capacitance

Notes:

Capacitors in Parallel

When capacitors are connected in parallel:

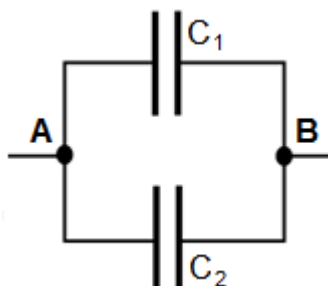

The voltage between point **A** and point **B** must be $\Delta V = V_A - V_B$, regardless of the path.

The charge on capacitor C_1 must be $Q_1 = C_1 \Delta V$, and the charge on capacitor C_2 must be $Q_2 = C_2 \Delta V$.

The total charge must be:

$$Q_1 + Q_2 = C_1 \Delta V + C_2 \Delta V = (C_1 + C_2) \Delta V$$

Therefore:

$$C_{eq} = \frac{Q_{total}}{\Delta V} = \frac{Q_1 + Q_2}{\Delta V} = C_1 + C_2$$

Generalizing this relationship, when capacitors are arranged in parallel, the total capacitance is the sum of the capacitances of the individual capacitors:

$$C_{eq} = C_1 + C_2 + C_3 + \dots$$

Use this space for summary and/or additional notes:

Capacitors in Series

In a series circuit, the voltage from one end to the other is divided among the components.

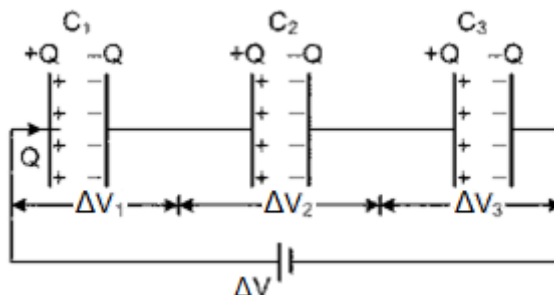

Note that the segment of the circuit that goes from the right side of C_1 to the left side of C_2 is isolated from the rest of the circuit. Current does not flow through a capacitor, which means charges cannot enter or leave this segment. Because charge is conserved (electrical charges cannot be created or destroyed), this means the negative charge on C_1 (which is $-Q_1$) must equal the positive charge on C_2 (which is $+Q_2$).

By applying this same argument across each of the capacitors, *all of the charges across capacitors in series must be equal to each other and equal to the total charge in that branch of the circuit.* (Note that this is true regardless of whether C_1 , C_2 and C_3 have the same capacitance.)

Therefore: $Q = Q_1 = Q_2 = Q_3$

Because the components are in series, we also know that $\Delta V = \Delta V_1 + \Delta V_2 + \Delta V_3$

Because $\Delta V = \frac{Q}{C}$:

$$\Delta V = \frac{Q_1}{C_1} + \frac{Q_2}{C_2} + \frac{Q_3}{C_3}$$

Because $Q = Q_1 = Q_2 = Q_3$:

$$\Delta V = \frac{Q}{C_1} + \frac{Q}{C_2} + \frac{Q}{C_3} = Q \left(\frac{1}{C_1} + \frac{1}{C_2} + \frac{1}{C_3} \right)$$

$$\frac{\Delta V}{Q} = \frac{1}{C_{eq}} = \frac{1}{C_1} + \frac{1}{C_2} + \frac{1}{C_3}$$

Generalizing this relationship, when capacitors are arranged in series, the total capacitance is the sum of the capacitances of the individual capacitors:

$$\frac{1}{C_{eq}} = \frac{1}{C_1} + \frac{1}{C_2} + \frac{1}{C_3} + \dots$$

Use this space for summary and/or additional notes:

Mixed Series and Parallel Circuits

As with resistor networks, mixed circuits involving capacitors in series and in parallel can be simplified by replacing each set of capacitors with an equivalent capacitance, starting with the innermost set of capacitors and working outwards (much like simplifying an equation by starting with the innermost parentheses and working outwards).

Sample Problem:

Simplify the following circuit:

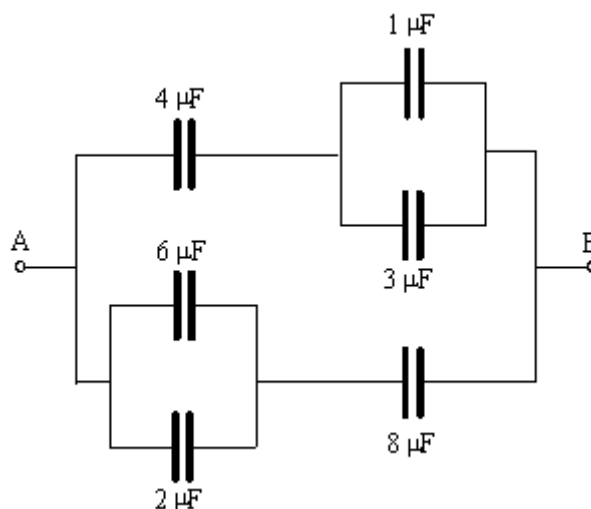

First we would add the capacitances in parallel. On top, $3\ \mu\text{F} + 1\ \mu\text{F} = 4\ \mu\text{F}$. On the bottom, $6\ \mu\text{F} + 2\ \mu\text{F} = 8\ \mu\text{F}$. This gives the following equivalent circuit:

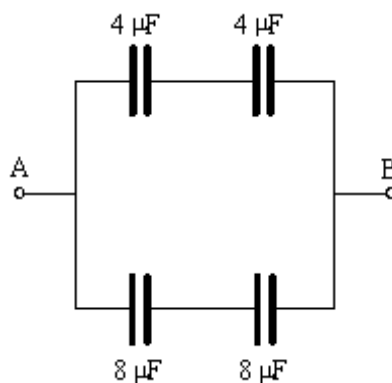

Use this space for summary and/or additional notes:

Next, we combine the capacitors in series on top:

$$\frac{1}{C_{eq}} = \frac{1}{C_1} + \frac{1}{C_2} = \frac{1}{4} + \frac{1}{4} = \frac{2}{4} = \frac{1}{2}$$

$$\frac{1}{C_{eq}} = \frac{1}{2}; \quad \therefore C_{eq} = 2 \mu\text{F}$$

and the capacitors in series on the bottom:

$$\frac{1}{C_{eq}} = \frac{1}{C_1} + \frac{1}{C_2} = \frac{1}{8} + \frac{1}{8} = \frac{2}{8} = \frac{1}{4}$$

$$\frac{1}{C_{eq}} = \frac{1}{4}; \quad \therefore C_{eq} = 4 \mu\text{F}$$

This gives the following equivalent circuit:

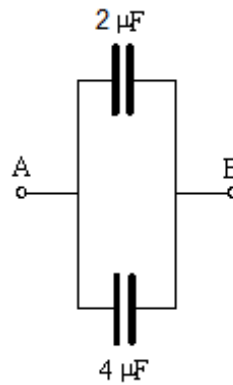

Finally, we combine the last two capacitances in parallel, which gives:

$$C_{eq} = C_1 + C_2 = 2 + 4 = 6 \mu\text{F}$$

Use this space for summary and/or additional notes:

Sample Problem

Q: Fill in the table for the following circuit:

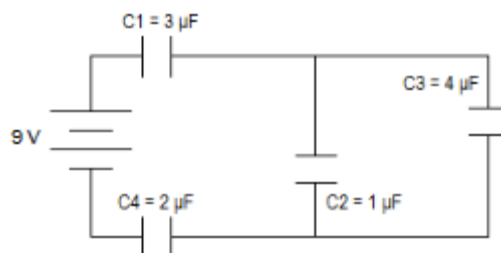

Quantity (unit)	Var.	C1	C2	C3	C4	Total
Voltage (V)	ΔV					9
Capacitance (μF)	C	3	1	4	2	
Charge (μC)						
Energy (μJ)						

A: Let's start by combining the two capacitors in parallel (C2 & C3) to make an equivalent capacitor.

$$C_* = C_2 + C_3 = 1 \mu\text{F} + 4 \mu\text{F} = 5 \mu\text{F}$$

Now we have three capacitors in series: C_1 , C_* , and C_4 :

$$\frac{1}{C_{total}} = \frac{1}{C_1} + \frac{1}{C_*} + \frac{1}{C_4} = \frac{1}{3} + \frac{1}{5} + \frac{1}{2} = 0.\bar{3} + 0.2 + 0.5 = 1.0\bar{3}$$

$$C_{total} = \frac{1}{1.0\bar{3}} = 0.9677 \mu\text{F}$$

Now we can calculate Q for the total circuit from $Q = C\Delta V$:

$$Q = C\Delta V = (9)(0.9677) = 8.710 \mu\text{C}$$

Now we have:

Quantity (unit)	Var.	C1	C2	C3	C4	Total
Voltage (V)	ΔV					9
Capacitance (μF)	C	3	1	4	2	0.9677
Charge (μC)	Q					8.710
Energy (μJ)	U					

Use this space for summary and/or additional notes:

Next, because the charge is equal across all capacitors in series, we know that $Q_1 = Q_* = Q_4 = Q_{total}$, which gives:

Quantity (unit)	Var.	C1	C2	C3	C4	Total
Voltage (V)	ΔV					9
Capacitance (μF)	C	3	1	4	2	0.9677
Charge (μC)	Q	8.710			8.710	8.710
Energy (μJ)	U					

Now we can calculate V_1 and V_4 from $Q = C\Delta V$.

We can also calculate the energy from $U_C = \frac{1}{2}Q\Delta V = \frac{1}{2}C(\Delta V)^2$

Quantity (unit)	Var.	C1	C2	C3	C4	Total
Voltage (V)	ΔV	2.903			4.355	9
Capacitance (μF)	C	3	1	4	2	0.9677
Charge (μC)	Q	8.710			8.710	8.710
Energy (μJ)	U	12.64			18.96	39.19

We know that voltages in series add, so $\Delta V_{total} = \Delta V_1 + \Delta V_* + \Delta V_4$, which means $9 = 2.903 + \Delta V_* + 4.355$, which gives $\Delta V_* = 1.742 \text{ V}$.

Because C_2 and C_3 (and therefore ΔV_2 and ΔV_3) are in parallel,

$$\Delta V_* = \Delta V_2 = \Delta V_3 = 1.742 \text{ V}$$

Quantity (unit)	Var.	C1	C2	C3	C4	Total
Voltage (V)	ΔV	2.903	1.742	1.742	4.355	9
Capacitance (μF)	C	3	1	4	2	0.9677
Charge (μC)	Q	8.710			8.710	8.710
Energy (μJ)	U	12.64			18.96	39.19

Finally, we can calculate Q from $Q = C\Delta V$ and U from $U_C = \frac{1}{2}Q\Delta V = \frac{1}{2}C(\Delta V)^2$:

Quantity (unit)	Var.	C1	C2	C3	C4	Total
Voltage (V)	ΔV	2.903	1.742	1.742	4.355	9
Capacitance (μF)	C	3	1	4	2	0.9677
Charge (μC)	Q	8.710	1.742	6.968	8.710	8.710
Energy (μJ)	U	12.64	1.52	6.07	18.96	39.19

Use this space for summary and/or additional notes:

Homework Problems

1. (S) Fill in the table for the following circuit:

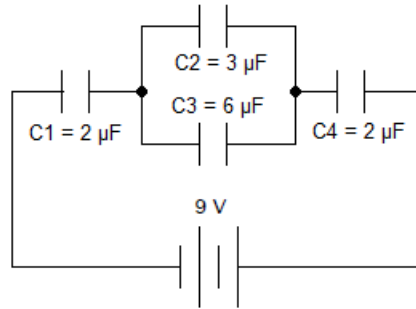

Quantity (unit)	Var.	C1	C2	C3	C4	Total
Voltage (V)	ΔV					9
Capacitance (μF)	C	2	3	6	2	
Charge (μC)	Q					
Energy (μJ)	U					

Use this space for summary and/or additional notes:

2. **(M)** Fill in the table for the following circuit:

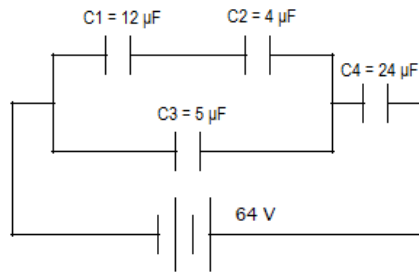

Quantity (unit)	Var.	C1	C2	C3	C4	Total
Voltage (V)	ΔV					64
Capacitance (μF)	C	12	4	5	24	
Charge (μC)	Q					
Energy (μJ)	U					

Use this space for summary and/or additional notes: